







EXPORT CATALOGUE

CAR TYRE CHANGERS ***& Original Accessories***



EFFECTIVE FROM JANUARY 2024
REL. MARCH 2024

COLOR TABLE

Standard		RAL 3002	Red	→ /16
Optional		RAL 1007	Yellow	→ /40
Optional		RAL 5015	Blue	→ /25
Optional		RAL 9006	Light Grey	→ /36

NEXION SPA reserves the right to change the specifications of its products at any time without prior notice. The company declines all responsibility in the event of claims deriving from the use of non-original accessories or spare parts with consequent forfeiture of the EC declaration of conformity.

SEMI-AUTOMATIC TYRE CHANGERS

TECO 20 SPECIAL	4
TECO 21	5
TECO 22	6
TECO 270 BIKE	7
TECO 270	8
TECO 28 SPECIAL	9
OPTIONAL ACCESSORIES FOR SEMI-AUTOMATIC TYRE CHANGERS	10

AUTOMATIC TYRE CHANGERS

TECO 35	21
TECO 45	22
TECO 35 RACING	23
TECO 380	24
TECO 380 WITH HELPER	25
TECO 480	26
TECO 480 WITH HELPER	27
TECO 40	28
OPTIONAL ACCESSORIES FOR AUTOMATIC TYRE CHANGERS	29

AUTOMATIC - LEVER-LESS TYRE CHANGERS

TECO 380 TOP	38
TECO 480 TOP	39
TECO 40 TOP	40
TECO 100 VARIANT	41
TECO EVEREST	42
TECO TH 32 ULTRA	43
OPTIONAL ACCESSORIES FOR AUTOMATIC LEVER-LESS TYRE CHANGERS	44

WDK APPROVED PRODUCT

TECO 380 WDK	59
TECO 380 TOP WDK	59
TECO 480 TOP WDK	59

PRODUCTS FEATURES LEGEND

MN	Manual control of the working arm
PN	Pneumatic control of the working arm
GP	Inflating pedal
T.I.	Tubeless inflating device
CRT	Mounting head quick change device
2V	2 speed
MI	Motoinverter 2 speed
SX	Swing arm: left movement
STT	Bead breaking system with blade
IPL2	Pneumatic lift
ML	Manual wheel locking system
AL	Pneumatic wheel locking system
WDK	WDK omologation

TECO20 SPECIAL



STANDARD ACCESSORIES



Code	Electric Supply	Description	
0-11604505/16	400V - 3Ph - 50/60Hz	TECO 20 Special MN	
0-11604501/16	230V - 1Ph - 50Hz	TECO 20 Special MN	

STANDARD ACCESSORIES



PLASTIC PROTECTIONS



Code	Electric Supply	Description	
0-11618902/16	400V - 3Ph - 50/60Hz	TECO 21 MN	
0-11618701/16	230V / 1Ph / 50Hz	TECO 21 MN	
0-11610702/16	400V - 3Ph - 50/60Hz	TECO 21 GP MN	

STANDARD ACCESSORIES

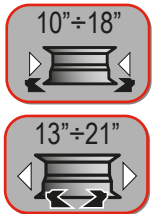
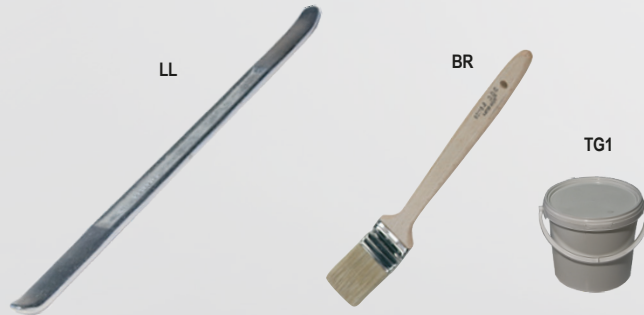

Code	Electric Supply	Description	
0-11636202/16	400V - 3Ph - 50/60Hz	TECO 22 MN	
0-11636201/16	230V - 1Ph - 50Hz	TECO 22 MN	

TECO270 BIKE



STANDARD ACCESSORIES

X5



X10



IG.P



TG1



LEVA



Code	Electric Supply	Description	
0-11638201/16	400V/3Ph/50Hz	TECO 270 BIKE	
0-11638202/16	230V/3Ph/50Hz	TECO 270 BIKE	
0-11638203/16	230V/1Ph/50Hz	TECO 270 BIKE	
0-11638204/16	230V/1Ph/60Hz	TECO 270 BIKE	
0-11638205/16	115V/1Ph/60Hz	TECO 270 BIKE	

TECO270



STANDARD ACCESSORIES

X5



X10



IG.P



TG1



LEVA

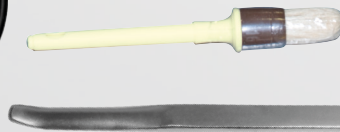

Code	Electric Supply	Description	
0-11634601/16	400V - 3Ph - 50Hz	TECO 270 MN	
0-11634602/16	200/230V - 1Ph - 50Hz	TECO 270 MN	
0-11634701/16	400V - 3Ph - 50Hz	TECO 270 T.I. - MN	
0-11634702/16	200/230V - 1Ph - 50Hz	TECO 270 T.I. - MN	
0-11634712/16	115V - 1Ph - 60Hz	TECO 270 T.I. - MN	
0-11634606/16	12V	TECO 270 MN	

TECO 28 SPECIAL



STANDARD ACCESSORIES

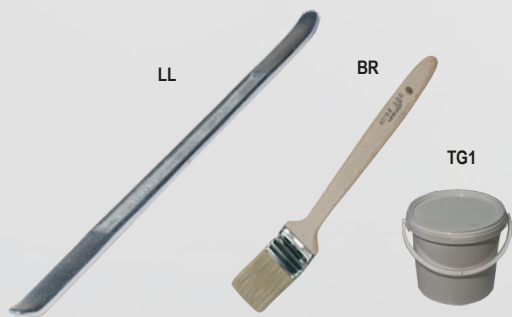







Code	Electric Supply	Description
0-11636702/16	400V - 3Ph - 50/60Hz	TECO 28 Special T.I. - MN
0-11636701/16	400V - 3Ph - 50Hz	TECO 28 Special T.I. - MN - 2V
TECO 28 SPECIAL WITH HELPER MOUNTED		
Code	Electric Supply	Description
0-13600200/16	400V - 3Ph - 50/60Hz	TECO 28 Special T.I. - MN with UPH S26 & BPS mounted



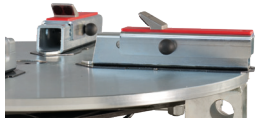





OPTIONAL ACCESSORIES FOR SEMI-AUTOMATIC TYRE CHANGERS

Image	Description	Code		TECO 20 SPECIAL	TECO 21	TECO 22	TECO 270 BIKE	TECO 270	TECO 28 SPECIAL
TURNTABLE ADAPTORS									
	UCA Set of 4 motocross clamps.	8-11600118		0	0	-	-	-	-
	ATV adaptors kit.(4 pcs).	8-11600119		0	0	-	-	-	-
	CKM Locking clamps kit (4 pcs).	8-11600121		0	0	-	-	-	-
	GKS Plastic protections kit (4 pcs).	8-11600122		0	0	-	-	-	-
	GKS-UKA Plastic protections kit for cross wheels (4 pcs).	8-11600376		0	0	-	-	-	-
	GK GO-KART adaptors kit (4 pcs)..	8-11600123		0	0	-	-	-	-
	UWA24 Set of adaptors to increase outside clamping capacity by 6" (4 pcs).	100012100		-	-	0	-	0	0
	UMA Set of 4 motorcycle wheel adaptors. Changing the external tightening capacity max/min $\pm 5"$.	8-11600401		-	-	0	-	0	0







OPTIONAL ACCESSORIES FOR SEMI-AUTOMATIC TYRE CHANGERS

Image	Description	Code	TECO 20 SPECIAL	TECO 21	TECO 22	TECO 270 BIKE	TECO 270	TECO 28 SPECIAL
	AR10 Set of adaptors to reduce outside clamping capacity by 2".	8-11100043	-	-	0	-	0	0
	Racing bike turntable jaw kit 8"-26"	8-11100461	-	-	-	0	-	-
	ATV turntable jaw kit 5"-18"	8-11100462	-	-	-	0	-	-
PROTECTIONS FOR ALLOY RIMS								
	RCP-2 Plastic protections for alloy rims	140009900	-	-	0	-	0	0
	RCP-3 Plastic protections for alloy rims	8-11600200	-	-	0	-	0	0
	PPC Plastic protections for clamps (20 pcs).	063905800	-	-	0	-	0	0

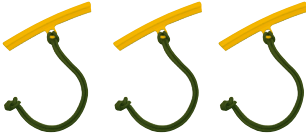





OPTIONAL ACCESSORIES FOR SEMI-AUTOMATIC TYRE CHANGERS

Image	Description	Code	TECO 20 SPECIAL	TECO 21	TECO 22	TECO 270 BIKE	TECO 270	TECO 28 SPECIAL
	PPI Integral plastic protections for clamps (4 pcs).	8-11600205	-	-	0	-	0	0
	IP1-2K Plastic inserts for standard steel mounting head (20 pcs)	063905900	0	0	0	0	0	0
	IP2-2K Plastic inserts for standard steel mounting head (20 pcs).	063906300	0	0	0	0	0	0
 x20	PPL Plastic protections for bead lever (20 pcs).	063906000	0	0	0	0	0	0
 x6	PPS Plastic protection for bead breaker blade (6 pcs).	801258383	-	-	0	-	0	0
	IP-RS Plastic inserts for mounting head RS (10 pcs).	8-11100045	0	0	0	0	0	0
PROTECTIONS FOR ALLOY RIMS								
 x10	10 front plastic insert for head tool	8-11100106	-	-	-	0	0	-
 x5	5 bottom plastic inserts for head tool	8-11100107	-	-	-	0	0	-
	SPU Plastic protections for UWA24 (4 pcs).	8-11600199	0	0	0	-	0	0





OPTIONAL ACCESSORIES FOR SEMI-AUTOMATIC TYRE CHANGERS

Image	Description	Code		TECO 20 SPECIAL	TECO 21	TECO 22	TECO 270 BIKE	TECO 270	TECO 28 SPECIAL
	PB Plastic protections for rim edge (3 pcs).	8-11120014		0	0	0	0	0	0
	PPM Plastic protection for motorcycle blade (6 pcs).	8-11600020		0	0	-	0	-	-
HEADS MOUNTING DEVICE									
	TAM/WING Steel tool head for cars and motorcycles (starting from serial # TRC197168)	8-11120050		-	-	-	0	0	-
 X10	MPK5 Spare kit of tool-head plastic protections (for TAM/WING)	8-11100369		-	-	-	0	0	-
	TPA-Wing - Full Assembly plastic tool-head kit with adapter (starting from serial # TRC197168)	8-11400329		-	-	-	0	0	-
	TPA-Wing Full Assembly plastic tool-head kit with adapter (before serial #TRC197168)	8-11400334		-	-	-	0	0	-
	TPA-Wing single plastic tool-head	8-11400330		-	-	-	0	0	-





OPTIONAL ACCESSORIES FOR SEMI-AUTOMATIC TYRE CHANGERS

Image	Description	Code	TECO 20 SPECIAL	TECO 21	TECO 22	TECO 270 BIKE	TECO 270	TECO 28 SPECIAL
	TMN Mounting/demounting tool-head for scooter wheels. Complete with plastic alloy rim protections. (starting from serial # TRC197168)	8-11100378	-	-	-	0	0	-
 X10	MPK6 Protection kit for new scooters m/d head (for TMN scooter).	8-11100370	-	-	-	0	0	-
	UPA Plastic mounting head complete with support.	801250309	0	0	0	-	0	0
	Kit UPA Plastic mounting head. For special models equipped with Teco quick change device.	8-11600193	-	-	-	-	-	0
	CRT CH 36 Traditional change device for mounting heads Ø36. Heads not included.	8-11600001	0	0	0	-	0	-
	RS Mounting head for projecting spoke rims.	8-11100011	0	0	0	0	0	0
	TRS Mounting head for scooter wheels. (up to sign TRC 197167)	801252083	0	0	0	-	-	0



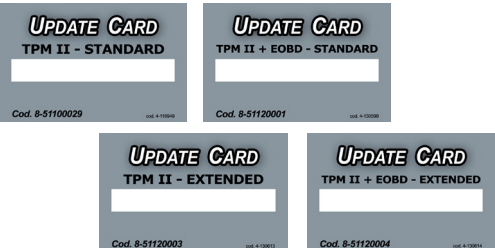

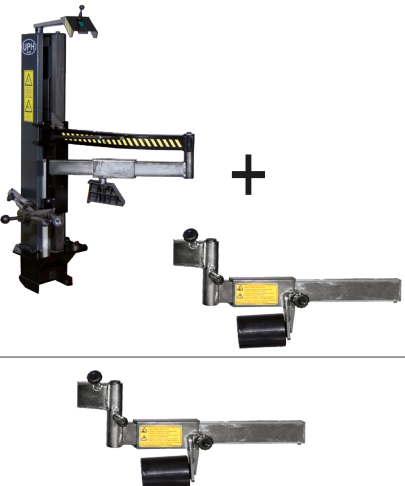
OPTIONAL ACCESSORIES FOR SEMI-AUTOMATIC TYRE CHANGERS

Image	Description	Code	TECO 20 SPECIAL	TECO 21	TECO 22	TECO 270 BIKE	TECO 270	TECO 28 SPECIAL
	KIT PR Mounting roller. For tyres having diameter less than 8".	8-11600117	0	0	0	-	-	-
	Kit M Hub Ø41 allowing to use the Teco quick change device system.	8-11600143	-	-	-	-	-	0
ADDITIONAL ACCESSORIES								
	TPM-02 Device for checking operation of TPMS sensors (reader and programmer)	6015001300	0	0	0	-	0	0
	OBD KIT	8-64500013	0	0	0	-	0	0
	Kit TPM-02 PLUS (reader and programmer, kit OBD included)	6015001391	0	0	0	-	0	0





OPTIONAL ACCESSORIES FOR SEMI-AUTOMATIC TYRE CHANGERS

Image	Description	Code	TECO 20 SPECIAL	TECO 21	TECO 22	TECO 270 BIKE	TECO 270	TECO 28 SPECIAL
	Subscription 12M TPM-02 standard	8-51100029	0	0	0	-	0	0
	Subscription 12M TPM-02 extended	8-51120003	0	0	0	-	0	0
	Subscription 12M TPM-02 PLUS	8-51120001	0	0	0	-	0	0
	Subscription 12M TPM-02 PLUS extended	8-51120004	0	0	0	-	0	0
	Bluetooth printer	6015001360	0	0	0	-	0	0
	UPH S22 Left side universal pneumatic device to easily mount and demount particularly tough or low profile tyres.	8-11600028/00	-	0	0	-	-	-
	UPH S22 + BPS Universal pneumatic device with supplementary pressing arm	8-11600029/00	-	0	0	-	-	-
	UPH S26 Left side universal pneumatic device to easily mount and demount particularly tough or low profile tyres	8-11600032/00	-	-	-	-	-	0
	UPH S26 + BPS Universal pneumatic device with supplementary pressing arm	8-11600033/00	-	-	-	-	-	0
	KIT BPS Supplementary pressing arm to be assembled on UPH help arm.	8-11600194	-	0	0	-	-	0



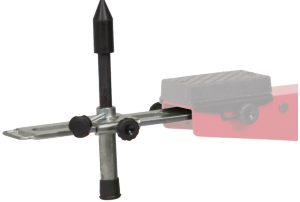

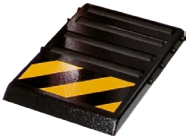
OPTIONAL ACCESSORIES FOR SEMI-AUTOMATIC TYRE CHANGERS

Image	Description	Code	TECO 20 SPECIAL	TECO 21	TECO 22	TECO 270 BIKE	TECO 270	TECO 28 SPECIAL
	Helper BPL	8-11120032	-	-	-	0	0	-
ADDITIONAL ACCESSORIES								
	HPG-RF Professional bead pressing clamp.	801262417	0	0	0	0	0	0
	HPG Plastic bead pressing clamp.	801435685	0	0	0	0	0	0
	KIT AI Lifting disc to prevent tyre lower re-beading. To be assembled on floating arm.	8-11600133	-	-	0	-	-	0
	PLS2 Pneumatic lift complete with roller rest having maximum working capacity of 60 kg	8-11600003	-	-	-	0	0	0







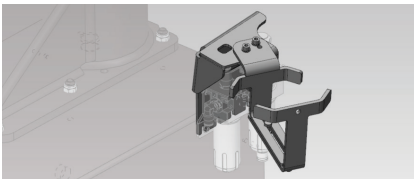
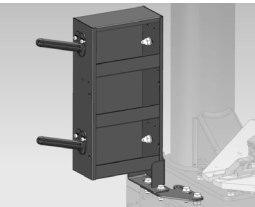

OPTIONAL ACCESSORIES FOR SEMI-AUTOMATIC TYRE CHANGERS

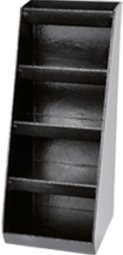
Image	Description	Code	TECO 20 SPECIAL	TECO 21	TECO 22	TECO 270 BIKE	TECO 270	TECO 28 SPECIAL
IMAGE NON AVAILABLE	KAPLS28 forntal label (5 pcs)	8-11600097	-	-	-	-	-	0
	KIT AS Additional spacer for bead breaker support.	8-11600196	-	0	0	-	-	0
	KIT SR Motorcycle bead breaker wheel support..	8-11600116	0	-	-	-	-	-
	CR Centring kit for ATV wheels. Accessory for wheel support KIT SR.	8-11600120	0	-	-	-	-	-
	BBR Bead breaker roller board. To be fi xed on fl oor.	080000060	0	0	0	0	0	0
	Removable platform for bike wheels	8-11100463	-	-	-	0	-	-

OPTIONAL ACCESSORIES FOR SEMI-AUTOMATIC TYRE CHANGERS

Image	Description	Code	TECO 20 SPECIAL	TECO 21	TECO 22	TECO 270 BIKE	TECO 270	TECO 28 SPECIAL
	PRM Supplementary blade for motorcycle wheels. To be assembled on standard car blade.	080016900	-	-	0	-	0	0
	KIT BLAST Inflating device for tubeless tyres complete with shot handle and tank. For inflating pedal versions. Compatible only with machines in GP configuration - Inflating pedal	8-11600065	-	-	-	-	-	0
	IG.P Inflating gun for CE countries. (for NOT T.I. models)	8-11600126	0	0	0	0	0	0
	MAG Michelin inflating gun (for NOT T.I. models)	8-11600187	0	0	0	0	0	0
	Lube bracket 1-5 Kg	8-11120095	-	-	-	0	0	-
	Storage tray	8-11120092	-	-	-	0	0	-

OPTIONAL ACCESSORIES FOR SEMI-AUTOMATIC TYRE CHANGERS

Image	Description	Code		TECO 20 SPECIAL	TECO 21	TECO 22	TECO 270 BIKE	TECO 270	TECO 28 SPECIAL
	KIT PO Tool tray kit complete with fi xing bracket.	8-11600124		0	0	0	-	-	0
	ST Adhesive weight remover.	802461006		0	0	0	0	0	0
	SV Valve core screwdriver.	801461005		0	0	0	0	0	0
	BR Grease brush.	040000100		0	0	0	0	0	0
	AFR Pressure regulator complete with fi lter and manometer.	080017800		0	0	0	0	0	0
	AL Automatic lubricator.	8-11600188		0	0	0	0	0	0
	TG1 Grease bucket (1 kg)	8-11600125		0	0	0	0	0	0
	TG5 Grease bucket (5 kg)	8-11600206		0	0	0	0	0	0

TECO35



STANDARD ACCESSORIES



PLASTIC PROTECTIONS



Code	Electric Supply	Description
0-11601402/16	400V - 3Ph - 50/60Hz	TECO 35 MN
0-11601401/16	230V - 1Ph - 50Hz	TECO 35 MN
0-11601305/16	400V - 3Ph - 50Hz	TECO 35 MN - 2V
0-11601902/16	400V - 3Ph - 50/60Hz	TECO 35 GP - MN
0-11601505/16	400V - 3Ph - 50Hz	TECO 35 GP - MN - 2V
0-11616102/16	400V - 3Ph - 50/60Hz	TECO 35 T.I. - MN
0-11619902/16	400V - 3Ph - 50Hz	TECO 35 T.I. - MN - 2V

TECO 35 WITH HELPER MOUNTED

Code	Electric Supply	Description
0-13600300/16	400V - 3Ph - 50Hz	TECO 35 GP - MN - 2V with SPH A22 mounted

TECO45



STANDARD ACCESSORIES



ONLY FOR NOT T.I.
AND NOT GP VERSION

PLASTIC PROTECTIONS



Code	Electric Supply	Description
0-11637201/16	400V - 3Ph - 50/60Hz	TECO 45 MN
0-11637202/16	400V - 3Ph - 50Hz	TECO 45 MN - 2V
0-11615716/16	200/240V - 1Ph - 50/60Hz	TECO 45 MN - MI
0-11637101/16	400V - 3Ph - 50/60Hz	TECO 45 GP - MN
0-11637102/16	400V / 3Ph / 50Hz	TECO 45 GP - MN - 2V
0-11637301/16	400V / 3Ph / 50/60Hz	TECO 45 T.I. - MN
0-11637302/16	400V / 3Ph / 50Hz	TECO 45 T.I. - MN - 2V

TECO35 RACING



STANDARD ACCESSORIES



PLASTIC PROTECTIONS



Code	Electric Supply	Description
0-11605505/16	400V - 3Ph - 50/60Hz	TECO 35 Racing MN
0-11605001/16	230V - 1Ph - 50Hz	TECO 35 Racing MN
0-11605005/16	400V - 3Ph - 50Hz	TECO 35 Racing MN - 2V
0-11612505/16	400V - 3Ph - 50Hz	TECO 35 Racing PN - 2V
0-11610905/16	400V - 3Ph - 50/60Hz	TECO 35 Racing GP - MN
0-11602702/16	400V - 3Ph - 50Hz	TECO 35 Racing GP - MN - 2V
0-11605302/16	400V - 3Ph - 50/60Hz	TECO 35 Racing T.I. - MN
0-11605401/16	230V - 1Ph - 50Hz	TECO 35 Racing T.I. - MN
0-11605405/16	400V - 3Ph - 50Hz	TECO 35 Racing T.I. - MN - 2V
0-11608705/16	400V - 3Ph - 50Hz	TECO 35 Racing T.I. - PN - 2V

TECO380



STANDARD ACCESSORIES

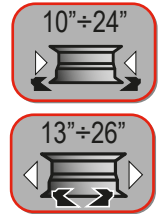

Code	Electric Supply	Description
0-11638302/16	400V - 3Ph - 50/60Hz	TECO 380 - MN - CRT
0-11638301/16	230V - 1Ph - 50Hz	TECO 380 - MN - CRT
0-11638304/16	400V - 3Ph - 50Hz	TECO 380 - MN - CRT - 2V
0-11638303/16	200/240V - 1Ph - 50/60Hz	TECO 380 - MN - CRT - MI
0-11638311/16	400V - 3Ph - 50Hz	TECO 380 - PN - CRT - 2V
0-11638331/16	400V - 3Ph - 50Hz	TECO 380 - GP - MN - CRT - 2V
0-11638341/16	200/240V - 1Ph - 50/60Hz	TECO 380 - GP - PN - CRT - MI
0-11638366/16	400V - 3Ph - 50Hz	TECO 380 - T.I. - MN - CRT - 2V
0-11638372/16	400V - 3Ph - 50Hz	TECO 380 - T.I. - PN - CRT - 2V
0-11638373/16	200/240V - 1Ph - 50/60Hz	TECO 380 - T.I. - PN - CRT - MI

TECO380 WITH HELPER



STANDARD ACCESSORIES



PLASTIC PROTECTIONS



TECO 380 with UPH+BPS



TECO 380 with SPH

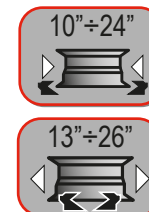

Code	Electric Supply	Description
0-13634521/16	400V - 3Ph - 50Hz	TECO 380 - MN - CRT - 2V with UPH A28 & BPS mounted
0-13634543/16	400V - 3Ph - 50Hz	TECO 380 - T.I. - PN - CRT - 2V with UPH A28 & BPS mounted
0-13634544/16	200/240V - 1Ph - 50/60Hz	TECO 380 - T.I. - PN - CRT - MI with UPH A28 & BPS mounted
0-13634561/16	400V - 3Ph - 50Hz	TECO 380 - GP - PN - CRT - 2V with SPH A28 mounted
0-13634562/16	200/240V - 1Ph - 50/60Hz	TECO 380 - GP - PN - CRT - MI with SPH A28 mounted
0-13634571/16	400V - 3Ph - 50Hz	TECO 380 - T.I. - MN - CRT - 2V with SPH A28 mounted
0-13634573/16	400V - 3Ph - 50Hz	TECO 380 - T.I. - PN - CRT - 2V with SPH A28 mounted

TECO480



STANDARD ACCESSORIES



RCP3_PLASTIC PROTECTIONS

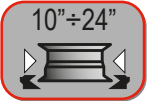

Code	Electric Supply	Description
0-11634803/16	400V - 3Ph - 50Hz	TECO 480 MN - CRT - 2V
0-11634801/16	400V - 3Ph - 50Hz	TECO 480 GP - PN - CRT - 2V
0-11634823/16	200/240V - 1PH - 50/60Hz	TECO 480 GP - PN - CRT - MI
0-11634816/16	400V - 3Ph - 50Hz	TECO 480 T.I. - PN - CRT - 2V
0-11634815/16	200/240V - 1PH - 50/60Hz	TECO 480 T.I. - PN - CRT - MI
0-11634809/16	400V - 3Ph - 50Hz	TECO 480 SX - GP - PN - CRT - 2V
0-11634807/16	200/240V - 1PH - 50/60Hz	TECO 480 SX - GP - PN - CRT - MI
0-11634814/16	400V - 3Ph - 50Hz	TECO 480 SX - T.I. - PN - CRT - 2V
0-11634824/16	200/240V - 1PH - 50/60Hz	TECO 480 SX - T.I. - PN - CRT - MI

teco480 WITH HELPER

STANDARD ACCESSORIES

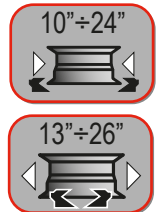
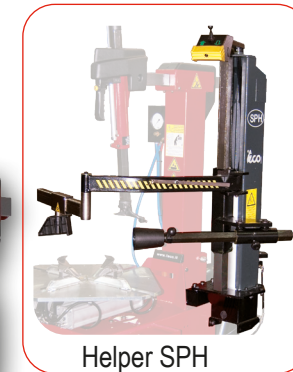
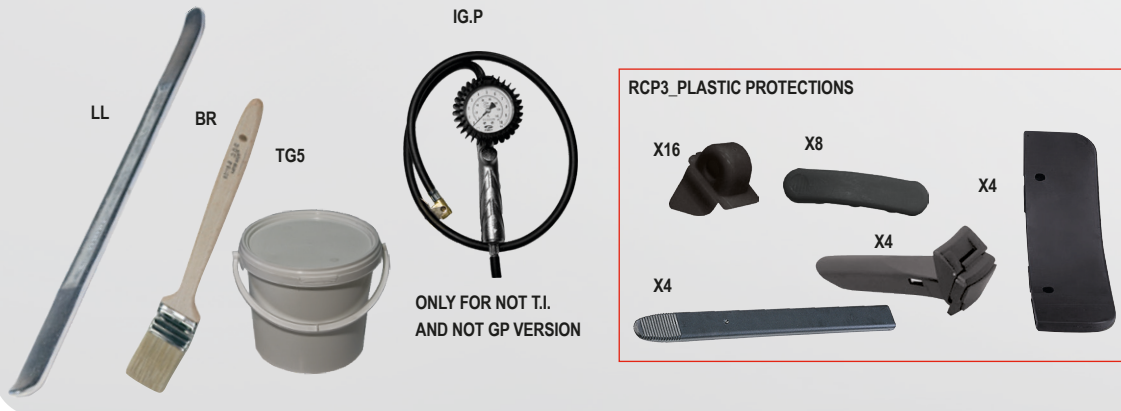

Code	Electric Supply	Description
0-13600501/16	400V - 3Ph - 50Hz	TECO 480 MN - CRT - 2V with UPH A28 & BPS mounted
0-13600500/16	400V - 3PH - 50Hz	TECO 480 T.I. - PN - CRT - 2V with UPH A28 & BPS mounted
0-13600600/16	200/240V - 1Ph - 50/60Hz	TECO 480 SX - GP - PN - CRT - MI with SPH A28 mounted

teco40







STANDARD ACCESSORIES



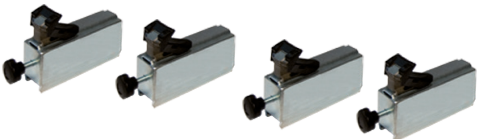





Code	Electric Supply	Description	
0-11603902/16	400V - 3Ph - 50Hz	TECO 40 T.I. - PN - CRT - 2V	
0-11603916/16	200/240V - 1Ph - 50/60Hz	TECO 40 T.I. - PN - CRT - MI	





OPTIONAL ACCESSORIES FOR AUTOMATIC TYRE CHANGERS

Image	Description	Code		TECO 35	TECO 45	TECO 35 RACING	TECO 36 SPECIAL	TECO 380	TECO 480	TECO 40
TURNTABLE ADAPTERS										
	UWA24 Wheel adapters to increase the turntable clamping capacity of 6" (4 pcs).	100012100		0	0	0	0	0	0	0
	UMA Motorcycle wheel adapters (4 pcs). Modification of the external table clamping capacity max/min $\pm 5"$.	8-11600401		0	0	0	0	0	0	0
	AR10 Adapters to reduce the minimum external clamping capacity of 2" (4 pcs).	8-11100043		0	0	0	0	0	0	0
	US TPH Universal spacer for TPH arm. To be used with UWA24, UMA and CRA.	8-11600051		-	-	-	0	0	0	0
ALLOY RIMS PROTECTION										
	RCP-2 Plastic protections for alloy rims	140009900		0	0	0	0	0	0	0



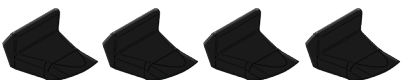
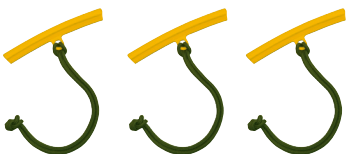



OPTIONAL ACCESSORIES FOR AUTOMATIC TYRE CHANGERS

Image	Description	Code								
			TECO 35	TECO 45	TECO 35 RACING	TECO 36 SPECIAL	TECO 380	TECO 480	TECO 40	
	RCP-3 Plastic protections for alloy rims	8-11600200	0	0	0	0	0	0	0	
	PPC Plastic protections for clamps (20 pcs).	063905800	0	0	0	0	0	0	0	
	PPI Integral plastic protections for clamps (4 pcs).	8-11600205	0	0	0	0	0	0	0	
	IP1-2K Plastic inserts for standard steel mounting head (20 pcs).	063905900	0	0	0	0	0	0	0	
ALLOY RIMS PROTECTION										
	IP2-2K Plastic inserts for standard steel mounting head (20 pcs).	063906300	0	0	0	0	0	0	0	
x20 	PPL Plastic protections for bead lever (20 pcs).	063906000	0	0	0	0	0	0	0	
x6 	PPS Plastic protection for bead breaker blade (6 pcs).	801258383	0	0	0	0	0	0	0	





OPTIONAL ACCESSORIES FOR AUTOMATIC TYRE CHANGERS

Image	Description	Code		TECO 35	TECO 45	TECO 35 RACING	TECO 36 SPECIAL	TECO 380	TECO 480	TECO 40
	IP-RS Plastic inserts for mounting head RS (10 pcs).	8-11100045		0	0	0	0	0	0	0
	SPU Plastic protections for UWA24 (4 pcs).	8-11600199		0	0	0	0	0	0	0
	PB Plastic protections for rim edge (3 pcs).	8-11120014		0	0	0	0	0	0	0
HEADS MOUNTING DEVICE										
	UPA Plastic mounting head complete with support.	801250309		0	0	0	0	0	0	0
	Kit UPA Plastic mounting head. For special models equipped with Teco quick change device.	8-11600193		-	-	-	0	0	0	0
	CRT CH 36 Traditional change device for mounting heads Ø36. Heads not included.	8-11600001		0	0	-	-	-	-	-
	CRT CH 41 Traditional change device for mounting heads Ø41. Heads not included.	8-11600002		-	-	0	-	-	-	-



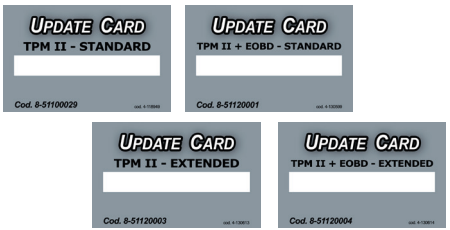

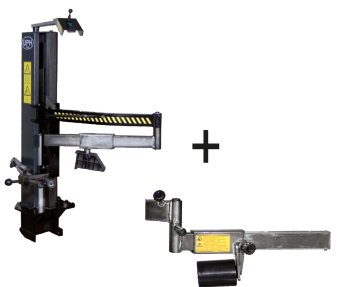
OPTIONAL ACCESSORIES FOR AUTOMATIC TYRE CHANGERS

Image	Description	Code		TECO 35	TECO 45	TECO 35 RACING	TECO 36 SPECIAL	TECO 380	TECO 480	TECO 40
	RS Mounting head for projecting spoke rims.	8-11100011		-	-	-	0	0	0	0
	TRS Mounting head for scooter wheels.	801252083		0	0	0	0	0	0	0
	Kit M Hub Ø41 allowing to use the Teco quick change device system.	8-11600143		-	-	-	0	0	0	0
ADDITIONAL ACCESSORIES										
	TPM-02 Device for checking operation of TPMS sensors (reader and programmer)	6015001300		0	0	0	0	0	0	0
	OBD KIT	8-64500013		0	0	0	0	0	0	0
	Kit TPM-02 PLUS (reader and programmer, kit OBD included)	6015001391		0	0	0	0	0	0	0





OPTIONAL ACCESSORIES FOR AUTOMATIC TYRE CHANGERS

Image	Description	Code							
			TECO 35	TECO 45	TECO 35 RACING	TECO 36 SPECIAL	TECO 380	TECO 480	TECO 40
	Subscription 12M TPM-02 standard	8-51100029	0	0	0	0	0	0	0
	Subscription 12M TPM-02 extended	8-51120003	0	0	0	0	0	0	0
	Subscription 12M TPM-02 PLUS	8-51120001	0	0	0	0	0	0	0
	Subscription 12M TPM-02 PLUS extended	8-51120004	0	0	0	0	0	0	0
	Bluetooth printer	6015001360	0	0	0	0	0	0	0
	UPH A22 Left side universal pneumatic device to easily mount and demount particularly tough or low profile tyres.	8-11600014/00	0	0	0	-	-	-	-
	UPH A22 + BPS Universal pneumatic device with supplementary pressing arm	8-11600015/00	0	0	0	-	-	-	-
	UPH A28 Left side universal pneumatic device to easily mount and demount particularly tough or low profile tyres.(for Teco 26).	8-11600017/00	-	-	-	0	0	0	0
	UPH A28 + BPS Universal pneumatic device with supplementary pressing arm	8-11600016/00	-	-	-	0	0	0	0
	KIT BPS Supplementary pressing arm to be assembled on UPH help arm.	8-11600194	0	0	0	0	0	0	0
	SPH A22 Right side universal pneumatic device to easily mount and demount particularly tough or low profile tyres.	8-11600068/00	0	-	0	-	-	-	-
	SPH A28 Right side universal pneumatic device to easily mount and demount particularly tough or low profile tyres.	8-11600069/00	-	-	-	0	0	0	0





OPTIONAL ACCESSORIES FOR AUTOMATIC TYRE CHANGERS

Image	Description	Code		TECO 35	TECO 45	TECO 35 RACING	TECO 36 SPECIAL	TECO 380	TECO 480	TECO 40
	TPH Right side automatic universal pneumatic device to easily mount and demount particularly tough or low profile tyres.	8-11600134		-	-	-	0	0	0	0
ADDITIONAL ACCESSORIES										
	HPG-RF Professional bead pressing clamp.	801262417		0	0	0	0	0	0	0
	HPG Plastic bead pressing clamp.	801435685		0	0	0	0	0	0	0
	KIT AI Lifting disc to prevent tyre lower re-beading. To be assembled on floating arm. UPH.	8-11600133		0	0	0	0	0	0	0
	PLS2 Pneumatic lift complete with roller rest having maximum working capacity of 60 kg	8-11600003		-	-	-	0	0	0	0







OPTIONAL ACCESSORIES FOR AUTOMATIC TYRE CHANGERS

Image	Description	Code							
			TECO 35	TECO 45	TECO 35 RACING	TECO 36 SPECIAL	TECO 380	TECO 480	TECO 40
IMAGE NOT AVAILABLE	KAPLS36 frontal label (5 pcs)	8-11600098	-	-	-	0	0	-	-
IMAGE NOT AVAILABLE	KAPLS480 frontal label(5 pcs)	8-11600099	-	-	-	-	-	0	-
ADDITIONAL ACCESSORIES									
	IPL Pneumatic lift complete with roller rest having maximum working capacity of 60 kg	8-11600369	-	-	-	-	-	-	0
	KIT AS Additional spacer for bead breaker support..	8-11600196	0	0	0	0	0	0	-
	Kit 3 DAS 3 spacers for bead breaker support. (for Teco40 and Teco42)	8-11600191	-	-	-	-	-	-	0
	BBR Bead breaker roller board. To be fixed on floor.	080000060	0	0	0	0	0	0	0
	PRM Supplementary blade for motorcycle wheels. To be assembled on standard car blade.	080016900	0	0	0	0	0	0	0

OPTIONAL ACCESSORIES FOR AUTOMATIC TYRE CHANGERS

Image	Description	Code							
			TECO 35	TECO 45	TECO 35 RACING	TECO 36 SPECIAL	TECO 380	TECO 480	TECO 40
	KIT BLAST Inflating device for tubeless tyres complete with shot handle and tank. Compatible only with machines in GP configuration - Inflating pedal	8-11600065	0	0	0	0	0	0	0
ADDITIONAL ACCESSORIES									
	IG.P Inflating gun for CE countries. (for NOT T.I. models)	8-11600126	0	0	0	0	0	0	0
	MAG Michelin inflating gun (for NOT T.I. models).	8-11600187	0	0	0	0	0	0	0
	KIT PO Tool tray kit complete with fixing bracket	8-11600124	0	0	0	0	0	0	0
	ST Adhesive weight remover.	802461006	0	0	0	0	0	0	0

OPTIONAL ACCESSORIES FOR AUTOMATIC TYRE CHANGERS

Image	Description	Code		TECO 35	TECO 45	TECO 35 RACING	TECO 36 SPECIAL	TECO 380	TECO 480	TECO 40
ADDITIONAL ACCESSORIES										
	SV Valve core screwdriver.	801461005		0	0	0	0	0	0	0
	BR Grease brush.	040000100		0	0	0	0	0	0	0
	AFR Pressure regulator complete with filter and manometer.	080017800		0	0	0	0	0	0	0
	AL Automatic lubricator.	8-11600188		0	0	0	0	0	0	0
	TG1 Grease bucket (1 kg)	8-11600125		0	0	0	0	0	0	0
	TG5 Grease bucket (5 kg)	8-11600206		0	0	0	0	0	0	0

TECO380 TOP



Code	Electric Supply	Description	
0-11638501/16	400V - 3Ph - 50Hz	TECO 380 TOP PN - 2V	
0-11638521/16	400V - 3Ph - 50Hz	TECO 380 TOP GP - PN - 2V	
0-11638522/16	200/240V - 1Ph - 50/60Hz	TECO 380 TOP GP - PN - MI	
0-11638541/16	400V - 3Ph - 50Hz	TECO 380 TOP T.I. - PN - 2V	
0-11638542/16	200/240V - 1Ph - 50/60Hz	TECO 380 TOP T.I. - PN - MI	

TECO480 TOP



STANDARD ACCESSORIES

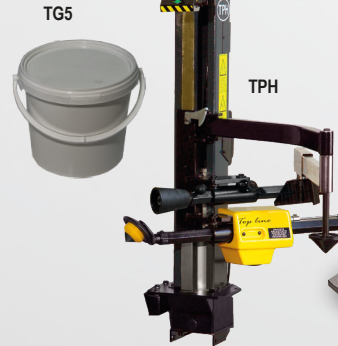

Code	Electric Supply	Description	
0-11634903/16	400V - 3Ph - 50Hz	TECO 480 TOP PN - 2V	
0-11634902/16	400V - 3Ph - 50Hz	TECO 480 TOP GP - PN - 2V	
0-11634901/16	200/240V - 1Ph - 50/60Hz	TECO 480 TOP GP - PN - MI	
0-11634906/16	400V - 3Ph - 50Hz	TECO 480 TOP T.I. - PN - 2V	
0-11634905/16	200/240V - 1Ph - 50/60Hz	TECO 480 TOP T.I. - PN - MI	

TECO40 TOP



STANDARD ACCESSORIES

LC

X3



BR



LL

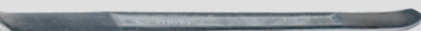

IG.P



ONLY FOR NOT T.I.
AND NOT GP MODELS

PLASTIC PROTECTIONS

X10

X10

X4



X4



TG5



TPH



LIFT IS NOT INCLUDED
IN THE EQUIPMENT

Code	Electric Supply	Description
0-11628505/16	400V - 3Ph - 50Hz	TECO 40 TOP - PN - 2V
0-11608605/16	400V - 3Ph - 50Hz	TECO 40 TOP - GP - PN - 2V
0-11606305/16	400V - 3Ph - 50Hz	TECO 40 TOP - T.I. - PN - 2V

TECO 100 VARIANT



STANDARD ACCESSORIES

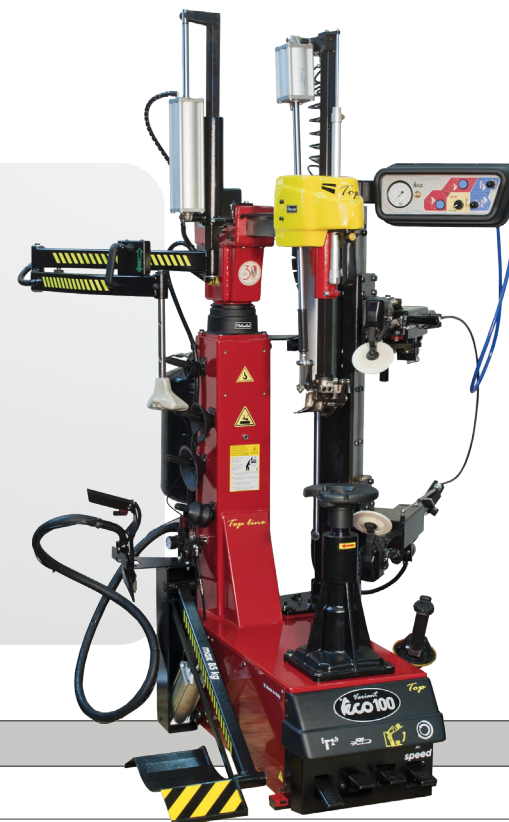

Code	Electric Supply	Description
0-11626405/16	400V - 3Ph - 50Hz	TECO 100 VARIANT GP - PN - ML - 2V
0-11626316/16	200/240V - 1Ph - 50/60Hz	TECO 100 VARIANT GP - PN - ML - MI WDK
0-11629505/16	400V - 3Ph - 50Hz	TECO 100 VARIANT GP - PN - AL - 2V
0-11629616/16	200/240V - 1Ph - 50/60Hz	TECO 100 VARIANT GP - PN - AL - MI WDK
0-11626401/16	400V - 3Ph - 50Hz	TECO 100 VARIANT GP - PN - ML - IPL2 - 2V
0-11626301/16	200/240V - 1Ph - 50/60Hz	TECO 100 VARIANT GP - PN - ML - IPL2 - MI WDK
0-11629501/16	400V - 3Ph - 50Hz	TECO 100 VARIANT GP - PN - AL - IPL2 - 2V
0-11629601/16	200/240V - 1Ph - 50/60Hz	TECO 100 VARIANT GP - PN - AL - IPL2 - MI WDK
0-11626201/16	200/240V - 1Ph - 50/60Hz	TECO 100 VARIANT STT - GP - PN - ML - IPL2 - MI
0-11629303/16	200/240V - 1Ph - 50/60Hz	TECO 100 VARIANT STT - GP - PN - AL - IPL2 - MI

TECO EVEREST



STANDARD ACCESSORIES



Code	Electric Supply	Description
0-11655012/16	200/230V - 1Ph - 50/60Hz	TECO EVEREST MI + bead pressing tool
0-11655022/16	200/230V - 1Ph - 50/60Hz	TECO EVEREST MI + bead pressing tool + IPL3 wheel lifter
0-11655032/16	200/230V - 1Ph - 50/60Hz	TECO EVEREST MI T.I. + bead pressing tool + IPL3 wheel lifter

teco TH 32 ULTRA



STANDARD ACCESSORIES

X2 MPR
COD. 801262417

REP
COD. 8-11120014

REPS
COD. 8-11120015

X3







X3

Code	Electric Supply	Description
0-11655101/16	200-230V-1Ph-50/60Hz	TECO TH 32 ULTRA BASE S.L. Bead pressing tool + side wheel lifter
0-11655111/16	200-230V-1Ph-50/60Hz	TECO TH 32 ULTRA VISTA P.L. Bead pressing tool + camera + front wheel lifter
0-11655121/16	200-230V-1Ph-50/60Hz	TECO TH 32 ULTRA TOP A. P.L. Bead pressing tool + AUTOMATIC cycle + camera + front wheel lifter + Inflatron





OPTIONAL ACCESSORIES FOR AUTOMATIC LEVER-LESS TYRE CHANGERS

Image	Description	Code		TECO 36 TOP	TECO 380 TOP	TECO 480 TOP	TECO 40 TOP	TECO 100 VARIANT	TECO EVEREST	TECO TH 32 ULTRA
TURNTABLE ADAPTORS										
	UWA24 Set of adaptors to increase outside clamping capacity by 6" (4 pcs).	100012100		0	0	0	0	-	-	-
	UMA Set of 4 motorcycle wheel adaptors. Changing the external tightening capacity max/min $\pm 5"$.	8-11600401		0	0	0	0	-	-	-
	AR10 Set of adaptors to reduce outside clamping capacity by 2".	8-11100043		0	0	0	0	-	-	-
	US TPH Universal spacer for TPH arm. To be used with UWA24, UMA and CRA.	8-11600051		0	0	0	0	-	-	-
ALLOY RIM PROTECTIONS										
	RCP-4 Plastic protections for alloy rims. For black Lever-Less head (up to serial number 160562929)	8-11600202		0	0	0	0	-	-	-



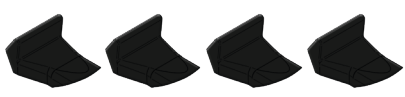
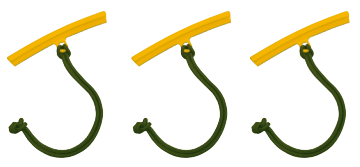

OPTIONAL ACCESSORIES FOR AUTOMATIC LEVER-LESS TYRE CHANGERS

Image	Description	Code								
			TECO 36 TOP	TECO 380 TOP	TECO 480 TOP	TECO 40 TOP	TECO 100 VARIANT	TECO EVEREST	TECO TH 32 ULTRA	
	RCP-6 Plastic protections for black Lever-Less head (up to serial number 160562929).	8-11600142	0	0	0	0	0	-	-	
	RCP-6A Plastic protections for Lever-Less head (20 pcs). For black Lever-Less head (up to serial number 160562929)	8-11600147	0	0	0	0	0	-	-	
	RCP-6B Plastic protections for Lever-Less head (20 pcs). For black Lever-Less head (up to serial number 160562929)	8-11600148	0	0	0	0	0	-	-	
	RCP-9 Plastic protections for alloy rims For chrome Lever- Less head (from serial number 160562930 up to serial number OOM111974)	8-11600192	0	0	0	0	-	-	-	
	RCP-11 Plastic protections for alloy rims For chrome Lever- Less head (from serial number 160562930 up to serial number OOM111974)"	8-11600366	0	0	0	0	0	-	-	
ALLOY RIM PROTECTIONS										
	RCP-11A Black plastic protections for chrome Lever-Less head (from serial number 160562930) up to serial number OMM111974)	8-11600367	0	0	0	0	0	-	-	
	RCP-11B Black plastic protections for chrome Lever-Less head (from serial number 160562930 up to serial number OOM111974)	8-11600368	0	0	0	0	0	-	-	







OPTIONAL ACCESSORIES FOR AUTOMATIC LEVER-LESS TYRE CHANGERS

Image	Description	Code		TECO 36 TOP	TECO 380 TOP	TECO 480 TOP	TECO 40 TOP	TECO 100 VARIANT	TECO EVEREST	TECO TH 32 ULTRA
	RCP-14 Spare kit of plastic protections for chrome Lever-Less head (from serial number OOM111975)	8-11600380		0	0	0	0	0	-	-
	RCP-14B Spare kit of plastic protections for chrome Lever-Less head (from serial number OOM111975)	8-11600381		0	0	0	0	0	-	-
	PPC Spare kit of plastic protections for clamps.(20 pcs).	063905800		0	0	0	0	-	-	-
	PPI Spare kit of integral plastic protections for clamps.(4 pcs).	8-11600205		0	0	0	0	-	-	-
 x6	PPS Plastic protection for bead breaker blade (6 pcs).	801258383		0	0	0	0	-	-	-
ALLOY RIM PROTECTIONS										
	SPU Plastic protections for UWA24 (4 pcs).	8-11600199		0	0	0	0	-	-	-
	PB Plastic protections for rim edge (3 pcs).	8-11120014		0	0	0	0	0	■	■







OPTIONAL ACCESSORIES FOR AUTOMATIC LEVER-LESS TYRE CHANGERS

Image	Description	Code		TECO 36 TOP	TECO 380 TOP	TECO 480 TOP	TECO 40 TOP	TECO 100 VARIANT	TECO EVEREST	TECO TH 32 ULTRA
	PPM Plastic protection for motorcycle blade (6 pcs).	8-11600020		0	0	0	0	0	-	-
SPECIFIC RIM PROTECTIONS FOR CENTRAL POST MODELS										
	RCP-5 Yellow plastic protections for alloy rims. For black Lever-Less head (up to serial number 160562929) (for Teco 100E too)	8-11600201		-	-	-	-	0	-	-
	RCP-10 Black plastic protections for alloy rims. For black Lever-Less head (from serial number 160562930 up to serial number OOM111974) (for Teco 100E too)	8-11600198		-	-	-	-	0	-	-
SPECIFIC RIM PROTECTIONS FOR CENTRAL POST MODELS										
	C75 Small plastic dragging cone for central locking shaft (10 pcs) (for Teco 100E too).	8-11600074		-	-	-	-	0	-	-
	CPC Clamping cone protection (10 pcs) (for Teco 100E too)	8-11600075		-	-	-	-	0	-	-

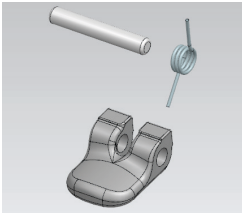



OPTIONAL ACCESSORIES FOR AUTOMATIC LEVER-LESS TYRE CHANGERS

Image	Description	Code		TECO 36 TOP	TECO 380 TOP	TECO 480 TOP	TECO 40 TOP	TECO 100 VARIANT	TECO EVEREST	TECO TH 32 ULTRA
	Protections kit for automatic locking	8-11100401		-	-	-	-	-	■	-
	PTS - Tyre bead protector (red)	8-11120013		0	0	0	0	0	■	■
	PBC - Short rim edge plastic protections (yellow)	8-11120015		0	0	0	0	0	■	■
PROTECTIONS FOR ALLOY WHEELS FOR MODELS WITHOUT PLATE										
	Plastic protection kit (5 pcs) for cone Ø 145 mm	8-11120058		-	-	-	-	-	0	0
	KPUL Spare tool plastic protection kit	8-11120035		-	-	-	-	-	0	0
	Protection tools kit	8-11120036		-	-	-	-	-	0	0



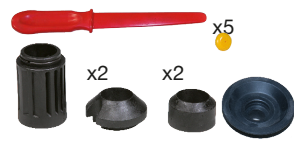

OPTIONAL ACCESSORIES FOR AUTOMATIC LEVER-LESS TYRE CHANGERS

Image	Description	Code		TECO 36 TOP	TECO 380 TOP	TECO 480 TOP	TECO 40 TOP	TECO 100 VARIANT	TECO EVEREST	TECO TH 32 ULTRA
	Retractable lever kit (1 pc for each item)	8-11120083		-	-	-	-	-	0	0
INFLATING DEVICE										
	KIT BLAST Inflating device for tubeless tyres complete with shot handle and tank. Compatible only with machines in GP configuration - Inflating pedal	8-11600065		0	0	0	0	0	-	-
	T.I. System kit	8-11120053		-	-	-	-	-	0	-
	T.I. System kit for Usa and Canada market	8-21120054		-	-	-	-	-	0	-
	IG.P Inflating gun for CE countries. (for NOT T.I. models)	8-11600126		0	0	0	0	0	0	-
	MAG Michelin inflating gun. (for NOT T.I. models)	8-11600187		0	0	0	0	0	0	-





OPTIONAL ACCESSORIES FOR AUTOMATIC LEVER-LESS TYRE CHANGERS

Image	Description	Code		TECO 36 TOP	TECO 380 TOP	TECO 480 TOP	TECO 40 TOP	TECO 100 VARIANT	TECO EVEREST	TECO TH 32 ULTRA
CLAMPING DEVICE										
	Special adapter kit for high van rims (/H=6400)	8-15100026		-	-	-	-	-	-	0
	Protection kit for automatic locking	8-11100412		-	-	-	-	-	-	■
	T.I. Tyre inflating kit	8-11100404		-	-	-	-	-	-	0
	T.I ASME Tyre inflating kit (for USA and Canada only)	8-15100038		-	-	-	-	-	-	0
CLAMPING ACCESSORIES FOR CENTRAL POST MODELS										
	Kit RR Clamping flange for reverse rims. (for Teco 100E and 100AL too) (maximum wheelbase 183 mm) Extensions H = 100 mm	8-11100039		-	-	-	-	0	0	0
	RRE Extension kit for reverse wheel flange, flange for close centre rims and non standard wheel kit. H + 23 mm / Diam. 25 mm	8-11100046		-	-	-	-	0	0	0





OPTIONAL ACCESSORIES FOR AUTOMATIC LEVER-LESS TYRE CHANGERS

Image	Description	Code		TECO 36 TOP	TECO 380 TOP	TECO 480 TOP	TECO 40 TOP	TECO 100 VARIANT	TECO EVEREST	TECO TH 32 ULTRA
	Kit for light commercial vehicles and pick-up rims. Rim hole diameter: max 158 mm	8-11100086		-	-	-	-	o	-	-
	Kit for light commercial vehicles and pick-up rims. Rim hole diameter: max 158 mm	8-11100037		-	-	-	-	-	o	o
	Special adapter kit for wide rims (H=28mm). Es. Porsche rear wheel	8-15100003		-	-	-	-	-	o	o
	H= 22mm spacer ring to be combined with P/N 8-11100037 / 8-11100086 / 8-15100003	8-15100040		-	-	-	-	o	o	o
CLAMPING ACCESSORIES FOR CENTRAL POST MODELS										
	Kit CCR T100E Fixing flange for close central hole rims (only for Teco 100 Variant ML) (for Teco 100E too)	8-11600087		-	-	-	-	o	-	o
	Kit CCR T100 Fixing flange for close central hole rims (only for Teco 100 Variant AL) (for Teco 100AL too)	8-11100038		-	-	-	-	o	o	-
	Kit ULS T100E Universal locking flange for non-standard wheels. Also for close central hole rims and reverse rims.(only for Teco 100 Variant ML) (for Teco 100E too)	8-11100110		-	-	-	-	o	-	o
	Kit ULS T100 Universal locking flange for non-standard wheels. Also for close central hole rims and reverse rims. (only for Teco 100 Variant AL) (for Teco 100AL too).	8-11100040		-	-	-	-	o	o	-





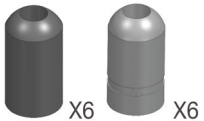

OPTIONAL ACCESSORIES FOR AUTOMATIC LEVER-LESS TYRE CHANGERS

Image	Description	Code		TECO 36 TOP	TECO 380 TOP	TECO 480 TOP	TECO 40 TOP	TECO 100 VARIANT	TECO EVEREST	TECO TH 32 ULTRA
AUXILIARY TOOLS										
	TPM-02 Device for checking operation of TPMS sensors (reader and programmer)	6015001300		0	0	0	0	0	0	0
	OBD KIT	8-64500013		0	0	0	0	0	0	0
	Kit TPM-02 PLUS (reader and programmer, kit OBD included)	6015001391		0	0	0	0	0	0	0
	Subscription 12M TPM-02 standard	8-51100029		0	0	0	0	0	0	0
	Subscription 12M TPM-02 extended	8-51120003		0	0	0	0	0	0	0
	Subscription 12M TPM-02 PLUS	8-51120001		0	0	0	0	0	0	0
	Subscription 12M TPM-02 PLUS extended	8-51120004		0	0	0	0	0	0	0
	Bluetooth printer	6015001360		0	0	0	0	0	0	0



OPTIONAL ACCESSORIES FOR AUTOMATIC LEVER-LESS TYRE CHANGERS

Image	Description	Code		TECO 36 TOP	TECO 380 TOP	TECO 480 TOP	TECO 40 TOP	TECO 100 VARIANT	TECO EVEREST	TECO TH 32 ULTRA
AUXILIARY TOOLS										
	Set of 6 "short" extensions. H = 80 mm	8-11100244		-	-	-	-	-	o	o
	Set of 6 "extra short" extensions. H = 60 mm	8-11100245		-	-	-	-	-	o	o
	Set of 6 "long" extensions. H = 125 mm	8-11100246		-	-	-	-	-	o	o
	Set of 12 plastic guard for extensions	8-11100284		-	-	-	-	-	o	o
	Set of 6 spherical extentions for new AUDI type rims	8-11100291		-	-	-	-	-	o	o





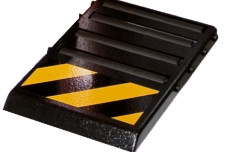

OPTIONAL ACCESSORIES FOR AUTOMATIC LEVER-LESS TYRE CHANGERS

Image	Description	Code							
			TECO 36 TOP	TECO 380 TOP	TECO 480 TOP	TECO 40 TOP	TECO 100 VARIANT	TECO EVEREST	TECO TH 32 ULTRA
AUXILIARY TOOLS									
	Sliding bead pressing clamp	8-11100120	-	-	-	-	-	0	0
	HPG-RF Professional bead pressing clamp.	801262417	0	0	0	0	0	0	0
	HPG Plastic bead pressing clamp.	801435685	0	0	0	0	0	0	0
	KIT AI Lifting disc to prevent tyre lower re-beading. To be assembled on UPH floating arm.	8-11600133	0	0	0	0	-	-	-
	KIT LC Short plastic levers to minimize bead stress during tyre demounting phase (5 pcs).	8-11600145	0	0	0	0	0	-	-
	PLS2 Pneumatic lift complete with roller rest having maximum working capacity of 60 kg	8-11600003	0	0	0	-	-	-	-



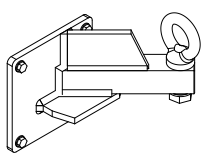

OPTIONAL ACCESSORIES FOR AUTOMATIC LEVER-LESS TYRE CHANGERS

Image	Description	Code							
			TECO 36 TOP	TECO 380 TOP	TECO 480 TOP	TECO 40 TOP	TECO 100 VARIANT	TECO EVEREST	TECO TH 32 ULTRA
AUXILIARY TOOLS									
IMAGE NOT AVAILABLE	KAPLS36 frontal label (5 pcs)	8-11600098	0	0	-	-	-	-	
IMAGE NOT AVAILABLE	KAPLS480 frontal label(5 pcs)	8-11600099	-	-	0	-	-	-	
	IPL Pneumatic lift complete with roller rest having maximum working capacity of 60 kg	8-11600369	-	-	-	0	-	-	
	KIT AS Additional spacer for bead breaker support.	8-11600196	0	0	0	-	-	-	
	Kit 3 DAS 3 spacers for bead breaker support (for Teco 42 too).	8-11600191	-	-	-	0	-	-	
	BBR Bead breaker roller board. To be fixed on floor.	080000060	0	0	0	0	0	-	

OPTIONAL ACCESSORIES FOR AUTOMATIC LEVER-LESS TYRE CHANGERS

Image	Description	Code		TECO 36 TOP	TECO 380 TOP	TECO 480 TOP	TECO 40 TOP	TECO 100 VARIANT	TECO EVEREST	TECO TH 32 ULTRA
	PRM Supplementary blade for motorcycle wheels. To be assembled on standard car blade.	080016900		0	0	0	0	-	-	-
AUXILIARY TOOLS										
	Kit R-LL Calibration device for Lever-Less head.	8-11600296		0	0	0	0	0	-	-
	LH Installation lifting hook.(for Teco 100E too)	8-11600197		-	-	-	-	0	-	-
	KIT PO Tool tray kit complete with fixing bracket.	8-11600124		0	0	0	0	0	-	-
	ST Adhesive weight remover.	802461006		0	0	0	0	0	0	0
	SV Valve core screwdriver.	801461005		0	0	0	0	0	0	0

OPTIONAL ACCESSORIES FOR AUTOMATIC LEVER-LESS TYRE CHANGERS

Image	Description	Code		TECO 36 TOP	TECO 380 TOP	TECO 480 TOP	TECO 40 TOP	TECO 100 VARIANT	TECO EVEREST	TECO TH 32 ULTRA
	BR Grease brush.	040000100		0	0	0	0	0	0	0
AUXILIARY TOOLS										
	AFR Pressure regulator complete with filter and manometer.	80017800		0	0	0	0	0	-	-
	AL Automatic lubricator.	8-11600188		0	0	0	0	0	-	-
	TG1 Grease bucket (1 kg)	8-11600125		0	0	0	0	0	0	0
	TG5 Grease bucket (5 kg)	8-11600206		0	0	0	0	0	0	0

OPTIONAL ACCESSORIES FOR AUTOMATIC LEVER-LESS TYRE CHANGERS

Image	Description	Code		TECO 36 TOP	TECO 380 TOP	TECO 480 TOP	TECO 40 TOP	TECO 100 VARIANT	TECO EVEREST	TECO TH 32 ULTRA
	<p>MAT TC Mobile Accessories Trolley</p>	<p>8-11100456</p>		-	-	-	-	0	0	0

teco380 TOP WDK



teco480 TOP WDK



STANDARD ACCESSORIES

RCP3_PLASTIC PROTECTIONS



LL HEAD PROTECTIONS



IG.P (36 SPECIAL-36 TOP)



Code	Electric Supply	Description
0-11638562/00	200-240V/1Ph/50-60Hz	TECO 380 TOP TI MI PN - 2V - vers. WDK
0-11634915/00	200-240V/1Ph/50-60Hz	TECO 480 TOP TI MI PN - 2V - vers. WDK



NEXION SPA - ITALY -

AUTOMOTIVE EQUIPMENT www.tecoautomotive.com - teco@teco.it

Sede operativa: Via Dinazzano, n. 4 - 42015 Prato di Correggio (RE) ITALY - Tel.: +39 0522 631562 - Fax +39 0522 642373

Cod. DPTC000183_TC_EX_03_2024